

AUX

INSTALLATION MANUAL

R32 Split Type Wall Mounted
Air-conditioner

MODELS

AJAN09HP115V1C
AJAN12HP115V1C
AJAN09HP230V1C
AJAN12HP230V1C
AJAN18HP230V1C
AJAN24HP230V1C
AFEB09HP115V1C
AFEB12HP115V1C
AFEB07HP230V1C
AFEB09HP230V1C
AFEB12HP230V1C
AFEB18HP230V2C
AFEB24HP230V1C
AMAR09HP115V1C
AMAR12HP115V1C
AMAR09HP230V1C
AMAR12HP230V1C
AMAR18HP230V1C
AMAR24HP230V1C
AJAN36HP230V1C
AJAN36HP230V2C



※ Please read this installation manual carefully and thoroughly before installing the unit.
※ Take care of this manual for future reference.

AUX CLOUD COMMERCE(USA) INC

400 Corporate Ct, South Plainfield, NJ 07080

CONTENTS

WARNING	1
SAFETY PRECAUTION	2
NOTICES FOR USAGE	4
NOTICES FOR INSTALLATION	5
INSTALLATION DIAGRAM	7
INSTALLATION FOR INDOOR UNIT	9
INSTALLATION FOR OUTDOOR UNIT	15
TESTING AND INSPECTION	18
CLEAN AND CARE	18
TROUBLESHOOTING	20
MAINTENANCE NOTICE	22

Note:

- All the illustrations in this manual are for explanation purpose only.
- Your air conditioner may be slightly different. The actual shape shall prevail.
- They are subject to change without notice for future improvement.
- When installing multi units, refer to the installation manual of the multi units for outdoor unit installation (Free Match DC Inverter Air-conditioner).

WARNING

NOTE: FCC and IC related content only applies to models with WiFi function.

※ **FCC WARNING**

WARNING: Changes or modifications to this unit not expressly approved by the party responsible for compliance could void the user's authority to operate the equipment.

※ **FCC STATEMENT**

This device complies with Part 15 of the FCC Rules. Operation is subject to the following two conditions:

(1) this device may not cause harmful interference, and (2) this device must accept any interference received, including interference that may cause undesired operation.

NOTE: This equipment has been tested and found to comply with the limits for a Class B digital device, pursuant to part 15 of the FCC Rules. These limits are designed to provide reasonable protection against harmful interference in a residential installation. This equipment generates, uses and can radiate radio frequency energy and, if not installed and used in accordance with the instructions, may cause harmful interference to radio communications. However, there is no guarantee that interference will not occur in a particular installation. If this equipment does cause harmful interference to radio or television reception, which can be determined by turning the equipment off and on, the user is encouraged to try to correct the interference by one or more of the following measures:

- Reorient or relocate the receiving antenna.
- Increase the separation between the equipment and receiver.
- Connect the equipment into an outlet on a circuit different from that to which the receiver is connected.
- Consult the dealer or an experienced radio/TV technician for help.

※ **IC STATEMENT**

This device complies with Industry Canada licence exempt RSS standard(s).

Operation is subject to the following two conditions: (1) this device may not cause interference, and (2) this device must accept any interference, including interference that may cause undesired operation of the device.





Le présent appareil est conforme aux CNR d'Industrie Canada applicables aux appareils radio exempts de licence.

L'exploitation est autorisée aux deux conditions suivantes : (1) l'appareil ne doit pas produire de brouillage, et (2) l'utilisateur de l'appareil doit accepter tout brouillage radioélectrique subi, même si le brouillage est susceptible d'en compromettre le fonctionnement.

※ **IC STATEMENT**

This equipment complies with FCC's and IC's RF radiation exposure limits set forth for an uncontrolled environment. The antenna(s) used for this transmitter must be installed and operated to provide a separation distance of at least 7.87in(20cm) from all persons and must not be collocated or operating in conjunction with any other antenna or transmitter. Installers must ensure that 7.87in(20cm) separation distance will be maintained between the device (excluding its handset) and users.

Cet appareil est conforme aux limites d'exposition au rayonnement RF stipulées par la FCC et l'IC pour une utilisation dans un environnement non contrôlé. Les antennes utilisées pour cet émetteur doivent être installées et doivent fonctionner à au moins 7.87in(20cm) de distance des utilisateurs et ne doivent pas être placées près d'autres antennes ou émetteurs ou fonctionner avec ceux-ci. Les installateurs doivent s'assurer qu'une distance de 7.87in(20cm) sépare l'appareil (à l'exception du combiné) des utilisateurs.

Symbol	Note	Explanation
 A2L	WARNING	This symbol shows that this appliance uses a flammable refrigerant. If the refrigerant is leaked and exposed to an external ignition source, there is a risk of fire.(Only for the AC with UL or ETL-MARKINH,UL60335-2-40)
	CAUTION	This symbol shows that the operation manual should be read carefully.
	CAUTION	This symbol shows that a service personnel should be handling this equipment with reference to the installation manual.
	CAUTION	This symbol shows that information is available such as the operating manual or installation manual.

WARNING

NOTE:

The Air conditioner with R32 refrigerant, if roughly treated, may cause serious harm to the human body or surrounding things.

- The room space and maximum refrigerant charge requirements are shown in the table to the right.
- If ice has formed on the unit, do not use means to accelerate the defrosting process other than those recommended by the manufacturer.
- Do not use any cleaners on the unit other than what's approved by the manufacture.
- Do not pierce or burn air conditioner and ensure that the refrigerant pipeline is not damaged.
- The appliance must be stored in a room without continuously operating ignition sources (for example: open flames, an operating gas appliance or an operating electric heater).
- Notice that the refrigerant may be odorless.
- The storage of the air conditioner should be in a location that's able to prevent unintentional damage to the unit.
- Be sure to follow all local codes and safety requirements.

Room Space and Maximum Refrigerant Charge Requirements

Refrigerant Type	Allowable Refrigerant Charge Amount, (oz(kg))	Min. Floor Area For Installation, (ft ² (m ²))
R32	< 64.9 (< 1.84)	75.35 (7)
	64.9~82.54 (1.84~2.34)	96.88 (9)
	82.58~100.18 (2.341~2.84)	113.02 (10.5)
	100.21~117.82 (2.841~3.34)	134.55 (12.5)
	117.85~135.45 (3.341~3.84)	150.69 (14)
	135.49~153.09 (3.841~4.34)	193.75 (18)

SAFETY PRECAUTIONS

Incorrect installation or operation by not following these instructions may cause harm or damage to people, properties, etc. The seriousness is classified by the following indications:

⚠ WARNING

This symbol indicates the possibility of death or serious injury.

⚠ CAUTION

This symbol indicates the possibility of injury or damage to properties.

⚠ WARNING

This appliance is not intended for use by persons (including children) with reduced physical, sensory or mental capabilities, or lack of experience and knowledge, unless they have been given supervision or instruction concerning use of the appliance by a person responsible for their safety.

Children should be supervised to ensure that they do not play with the appliance.

- Don't connect the ground wire to the gas pipeline, water pipeline, lightning rod, or telephone earth wire.
- The air conditioner must be grounded. Incomplete grounding may result in electric shocks.
- Do not pull the power cable. Pulling the power cable could result in damage to the unit and electrical shock.
- Always switch off the device and cut the power supply when the unit is not in use for long time so as to ensure safety.
- Don't cut off main power switch during operating or with wet hands. It may cause electric shock.
- Make sure that the system has its own dedicated electrical circuit and that all electrical work is conducted by an individual that is certified or licensed to do such work in the state or region in which the insulation is taking place.
- Always switch off the device and cut the power supply before performing any maintenance or cleaning, otherwise, it may cause electric shock or damage.
- Don't let the remote control or indoor unit get too wet. Exposure to excessive moisture may cause damage to the unit and or electrical shock.
- Don't install the air conditioner in a place where there is flammable gas or liquid unless the distance is equal to or greater than 3.28ft(1m) apart.
- Don't use any unapproved liquid or cleaning agent to clean the air conditioner.

SAFETY PRECAUTIONS

⚠ WARNING

- Don't attempt to repair the air conditioner by yourself. Incorrect repairs may cause fire or explosion.
- Contact a qualified service technician for all service requirements.
- Don't operate the air conditioner during a lightning storm. The power supply should be switched off to prevent danger or injury.
- Don't put hands or any objects into the air inlets or outlets. This may cause personal injury or damage to the unit.
- Please mount the system on a secure surface to prevent the unit from falling and causing injury or damage.
- Don't block air inlet or air outlet. Otherwise, the cooling or heating capacity will be diminished, or cause the system to stop operating.
- **The appliance shall be installed in accordance with national wiring regulations.**

This product contains fluorinated greenhouse gases.

- Refrigerant leakage will contribute to climate change.
- Never tamper with the refrigerant system or attempt repair without proper training and compliance to local and national codes.
- The refrigerant in this system has a lower global warming potential (GWP) than a refrigerant with higher GWP, if leaked to the atmosphere. This appliance contains a refrigerant fluid with a GWP equal to [675]. This means that if 35oz(1kg) of this refrigerant fluid would be leaked to the atmosphere, the impact on global warming would be [675] times higher than 35oz(1kg) of CO₂, over a period of 100 years.

Ensure the following objects are not under the indoor unit:

- Microwaves, ovens and other hot objects.
- Computers and other high electrostatic appliances.
- Electrical sockets.
- Items susceptible to water damage.

The piping between indoor and outdoor unit shall not be reused, unless they can be properly flushed and re-flared.

The specifications of the fuse are printed on the circuit board, such as: 3.15A/250V AC, etc.

⚠ CAUTION

- Don't operate the system with windows or doors open. Doing so will limit the system effectiveness.
- Don't stand on the top of the outdoor unit or place heavy objects on it. This could cause personal injuries or damage to the unit.
- Don't use the system for other purposes, such as drying clothes, preserving foods, etc.
- Appropriate adjustments of the setting temperature can prevent the waste of electricity.
- **If your air conditioner is not fitted with a supply cord and a plug, an anti-explosion all-pole switch must be installed in the fixed wiring and the distance between contacts should be no less than 3.0mm(0.12in).**

Regarding the installation of the air conditioners, please refer to the below paragraphs in this manual.

E-Waste

Disposal requirements:

- Don't dispose of electrical appliances as unsorted municipal waste, use separate collection facilities.
- Contact your local government for information regarding the collection systems available.
- If electrical appliances are disposed of in landfills or dumps, hazardous substances can leak into the groundwater and get into the ground water and food chain, damaging your health and well-being. Always follow local codes for disposal of e-waste.



NOTICES FOR USAGE

Operating Range

- Operating the unit outside the recommended temperature range may have an impact on the system performance.
- When the temperature is too high, the air conditioner may trip the circuit breaker causing the air conditioner to shut down.
- When the temperature is too low, the outdoor heat exchanger may generate excessive moisture, leading to water dripping from unit.
- In long-term cooling or dehumidification with a relative humidity of above 80%, doors and windows should be closed to prevent the indoor unit from generating too much water and causing leaks.

Range	Indoor	Outdoor
Cooling	60.8~89.6°F (16~32°C)	5~125.6°F (-15~52°C)
Heating	50~89.6°F (10~32°C)	-13~75.2°F (-25~24°C)

Notes For Heating

- The fan of the indoor unit will not start immediately when the heating cycle has started. The unit will warm up and then start blowing air to avoid blowing out cool air.
- When it is cold and wet outside, the outdoor unit will develop frost over the heat exchanger which over time will cause the system to start the defrost function.
- During defrost, the air conditioner will stop heating for about 5-12 minutes.
- Vapor may come out from the outdoor unit during defrost. This is not a malfunction, but a result of fast defrost.
- Heating will resume after defrost is complete.

Notes For Turning Off

- When the air conditioner is turned off, the main controller will automatically decide whether to stop immediately or after running for dozens of seconds with lower frequency and lower air speed.

Emergency Operation

- If the remote controller is lost or broken, use force switch button to operate the air conditioner.
- If this button is pushed with the unit OFF, the air conditioner will operate in Mode: AUTO with a set temperature of 77°F (25°C) and Fan speed: AUTO.
- If this button is pushed with the unit ON, the air conditioner will stop running.

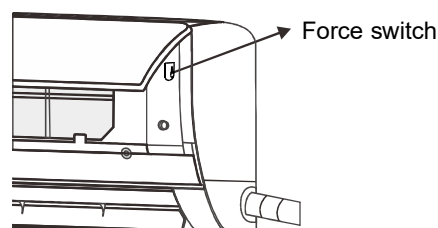

Airflow Direction Adjustment

1. Use up-down swing and left-right swing buttons on the remote controller to adjust the airflow direction. Refer to the operation manual of the remote controller for detail.
2. For models without left-right swing function, the air vent has to be moved manually.

Note: Move the air vents before the unit is in operation, or your finger might be injured. Never place your hand into the air inlet or outlet when the air conditioner is in operation.

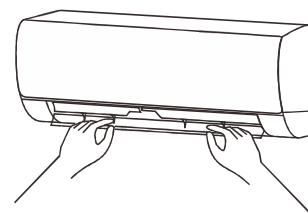

NOTICES FOR INSTALLATION

ⓘ Important Notices

- This unit must be installed by a certified contractor to avoid:
 - Damage to the unit
 - Refrigerant leaking into the atmosphere
 - Electrical shock
 - Burns from refrigerant
 - Other serious injury to include death
- Leak test must be made after installation.
- To move and install air conditioner to another place, please contact our local authorized contractor.

Unpacking Inspections

- Open the box and check air conditioner in area with good ventilation and without ignition source.
- Note: Operators are required to wear anti-static devices
- It is necessary to check whether there is refrigerant leakage before opening the box of outdoor machine; stop installing the air conditioner if leakage is found.
- The fire prevention equipment shall be prepared well before checking.
- Then check the refrigerant pipeline to see if there is any damage or leaks.

Safety Principles For Installing Air Conditioner

- Fire prevention device shall be prepared before installation.
- Keep installing site ventilated.(open the door and window)
- Ignition source, smoking and calling is not allowed to exist in area where R32 refrigerant located.
- Anti-static precautions in necessary for installing air conditioner, e.g. wear pure cotton clothes and gloves.
- Keep leak detector in working state during the installation.
- If R32 refrigerant leakage occurs during the installation, you shall immediately detect the concentration in indoor environment until it reaches a safe level.
- If refrigerant leakage affects the performance of the air conditioner, please immediately stop the operation, and the air conditioner must be vacuumed firstly and be returned to the maintenance station for processing.
- Keep electric appliance, power switch, plug, socket, high temperature heat source and high static away from the area underneath sidelines of the indoor unit.
- The air conditioner shall be installed in an accessible location to installation and maintenance, without obstacles that may block air inlets or outlets of indoor /outdoor units, and shall keep away from heat source, inflammable or explosive conditions.
- When installing or repairing the air conditioner and the connecting line is not long enough, the entire connecting line shall be replaced with the connecting line of the original specification; extension is not allowed.

Requirements For Installation position

- Avoid places of flammable or explosive gas leakage or where there is poor ventilation.
- Avoid places subject to strong electric/magnetic fields like microwaves and florescent lights.
- Avoid places like subject to noise and resonance like walls above a sleeping area.
- Avoid severe natural conditions (e.g. strong wind, direct sunshine or high temperature heat sources).
- Avoid places within the reach of children.
- Shorten the connection between the indoor and outdoor units as much as possible for best performance.
- Select a location where it is easy to perform service and repair.
- The outdoor unit shall not be installed in any way that could occupy an aisle, stairway, exit, fire escape, catwalk or any other public area.
- The outdoor unit shall be installed as far as possible from the doors and windows of the neighbors as well as plants.

Installation Environment Inspections

- Check nameplate of outdoor machine to make sure whether the refrigerant is R32.
- Check the floor space of the room. The space shall not be less than usable space in the specification.
- The outdoor unit shall be installed at a well-ventilated place.
- Check the surrounding environment of installation site: R32 shall not be installed in the enclosed reserved space of a building.
- When using electric drill to make holes in the wall, check first whether there is pre-buried pipeline for water, electricity and gas. It is suggested to use the reserved hole in the roof of the wall.

NOTICES FOR INSTALLATION

Requirements Of The Mounting Structure

- The mounting rack must meet the relevant national or industrial standards
- It is recommended that the mounting rack and its load carry surface shall be able to withstand 4 times or above the weight of the unit.
- The mounting rack of the outdoor unit shall be fastened with expansion bolts or as recommended by the manufacture.
- Ensure the secure installation regardless of what type of wall on which it is installed, to prevent potential dropping that could cause damage or injury.

Electrical Safety Requirements

- Be sure to use the correct rated voltage for the air conditioner and a dedicated circuit for the power supply,
 - Follow local and national codes for the correct power cable AWG.
 - The operating range is 90%-110% of the local rated voltage. But insufficient power supply malfunction, electrical shock, or fire. If the voltage instability, proposed to increase the voltage regulator.
 - The minimum clearance between the air conditioner and the combustibles is 4.9ft (1.5m) or greater.
 - Use the correct wire size and type for connecting the indoor unit to the outdoor unit.
 - The size of the interconnection cord, power cable, fuse, and switch needed is determined by the maximum current of the unit.
 - The maximum current is indicated on the nameplate located on the side panel of the unit.
- Refer to this nameplate to choose the right wire size, breaker, or switch.

Requirements for operations at raised height

- When carrying out installation at 6.6ft (2m) or higher above the base level, safety belts must be worn and ropes of sufficient strength be securely fastened to the outdoor unit, to prevent falling that could cause personal injury or death as well as property loss.

Grounding Requirements

- Be sure to properly ground the unit. Follow all local and national codes as applicable.
- Do not connect the grounding wire to a gas pipe, water pipe, lightning rod, telephone line, or a circuit poorly grounded to the earth.
- The grounding wire is specially designed and shall not be used for other purpose, nor shall it be fastened with a common tapping screw.
- Ensure that all electrical connects are securely fastened and connected to the correct terminals.
- Local and national electrical codes must be utilized.

Others

- The connection method of the air conditioner and the power cable and the interconnection method of each independent element shall be subject to the wiring diagram affixed to the machine.
- The model and rating value of the fuse shall be subject to the silkscreen on corresponding controller or fuse sleeve.

INSTALLATION DIAGRAM

Accessories

Read these Safety Considerations carefully before installing the drain pan heater.

After completing the installation, check if the unit operates properly during the start-up operation.

Packing list

Name	Quantity	Unit
Outdoor Unit	1	Set
Indoor Unit	1	Set
Remote Controller	1	PC
Batteries (AAA)	2	PC
Manual	2	Set
Drain pipe	1	PC
Remote controller holder	1	PC
Fixing screw for remote controller holder	2	PC
Flare nut	4	PC
Drain elbow	1	PC
Drain plug	15	PC
Mounting plate fixing screw	8	PC

Field-supplied Parts

Name	Quantity	Unit
Electrical wiring	1	Set
Connecting pipes	2	PC
Plastic Strap	1	ROLL
Pipe Protection Ring	1	PC
Putty	1	PACKET
Screws	≥5	PC

NOTE: Interconnection cord and sound deadening pads is optional accessories.

Tools Required

Phillips screwdriver	Level	Refrigerant Scale
Utility knife or scissors	Torque wrench	Wrench(or spanner)
Clamp on Amp Meter	Hole Saw	Manifold and Gauges
Hexagonal Wrench	Flare tool	Pipe Cutter
Vacuum Pump	Safety Glasses	Work Gloves

INSTALLATION DIAGRAM

Unit Parts

Indoor unit

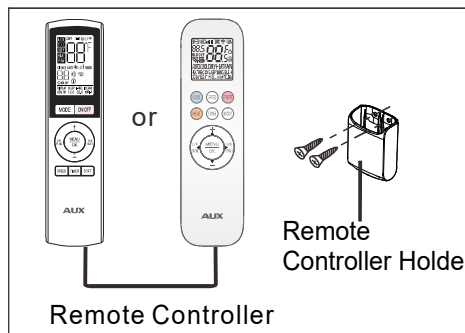
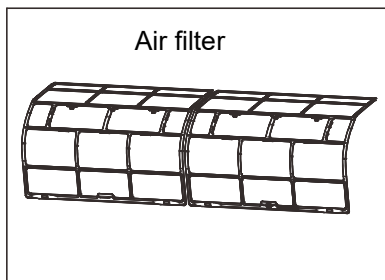
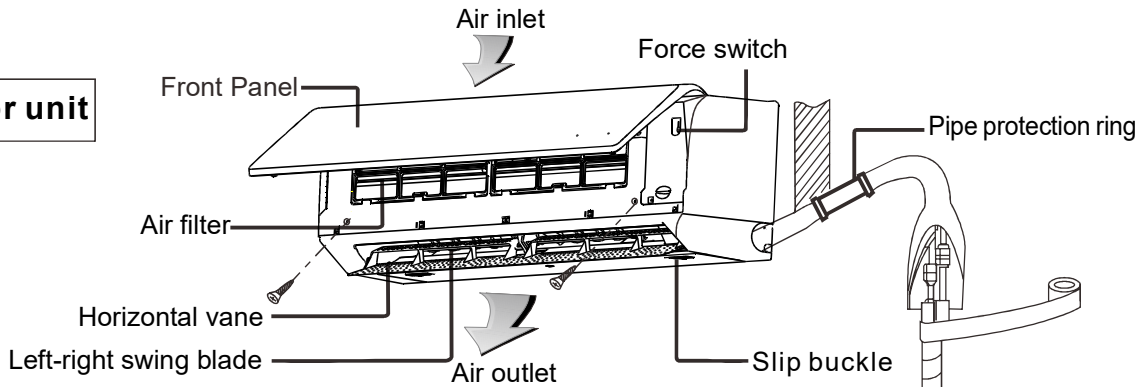

Outdoor unit

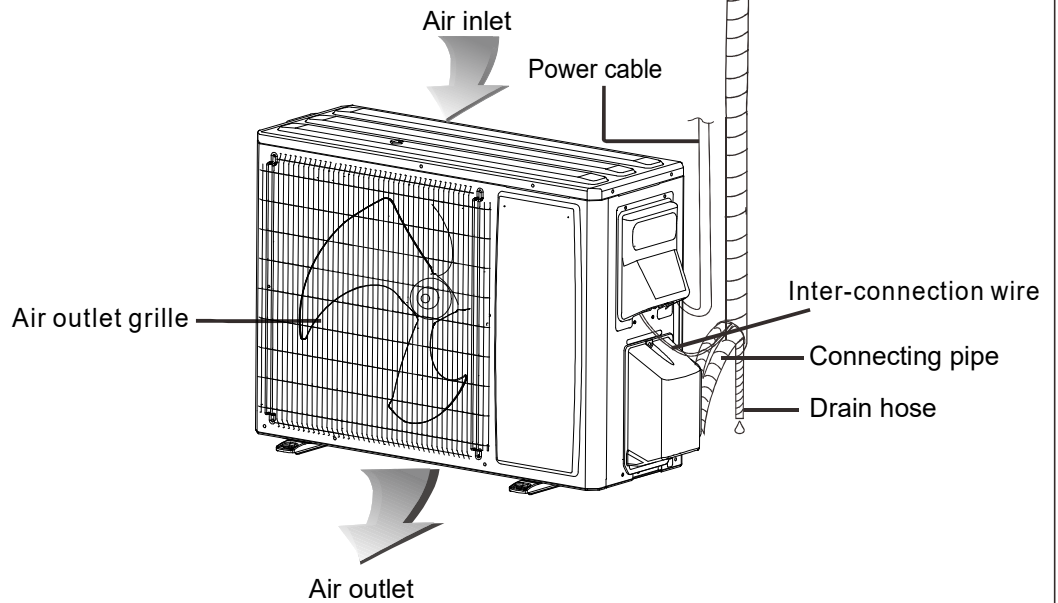

Note:

1. All the illustrations in this manual are for explanation purpose only.
2. Your air conditioner may be slightly different. The actual shape may vary.
3. They are subject to change without notice for future improvement.

INDOOR UNIT INSTALLATION

Dimension Drawing of Indoor Unit Installation

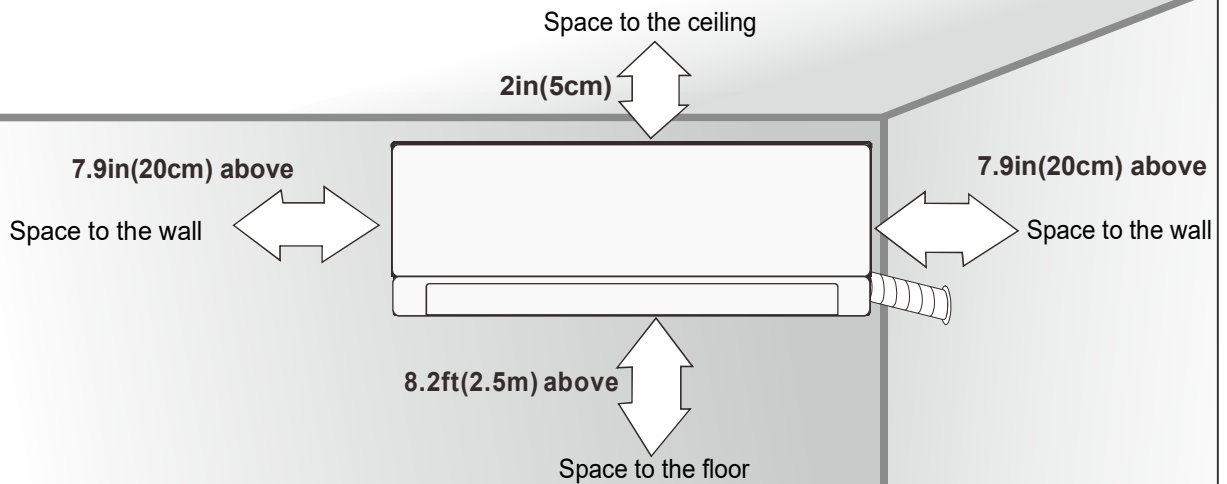

NOTE:

1. For safety requirements, the unit must be installed at least 8.2ft above the floor.
2. If installing the unit over a bookshelf or a shelf mounted to the wall, the unit must have 14in from the bottom of the unit to the top of the shelf.

Mounting Installation Plate

1. Ensure that the wall is strong enough to withstand the weight of the unit. Otherwise, it is necessary to reinforce the wall with plates, beams or pillars.
2. Use the "+" Phillips type screws in at least 5 suitable screws holes to fasten the plate to the wall.
3. Make sure the plate is horizontally level on the wall and there is enough room from the plate to the wall and ceiling to mount the unit.
4. Pull the mounting plate by hand after the installation, to confirm whether it is solid.
5. Use the installation dimensions to locate and punch holes (see figure)

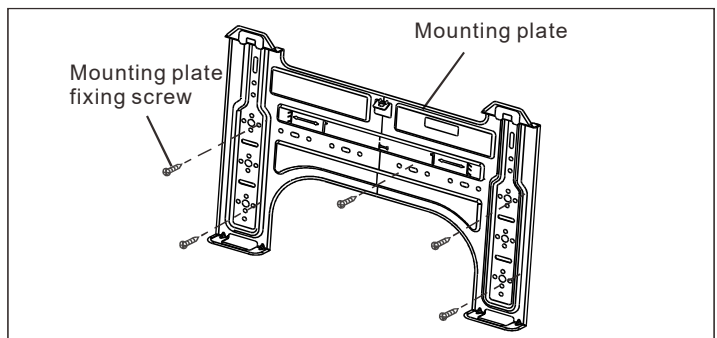

Installation plate 09/12

Unit: in (mm)

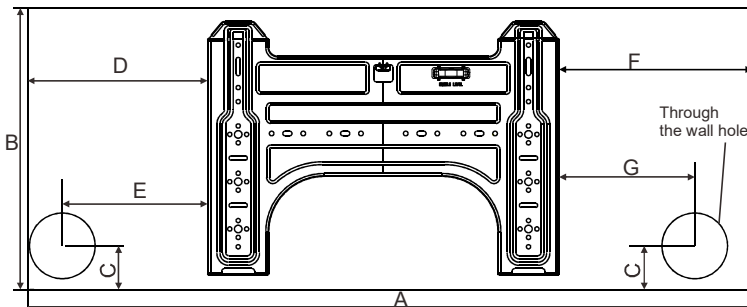

Dimension Model	07/09	12
A	30.47 (774)	32.84 (834)
B	11.85(301)	
C	1.85(47)	1.46 (37)
D	7.56(192)	8.43 (214)
E	6.10(155)	7.01 (178)
F	8.11(206)	9.61 (244)
G	5.70(145)	5.67 (144)

Installation plate 18/24

Unit: in (mm)

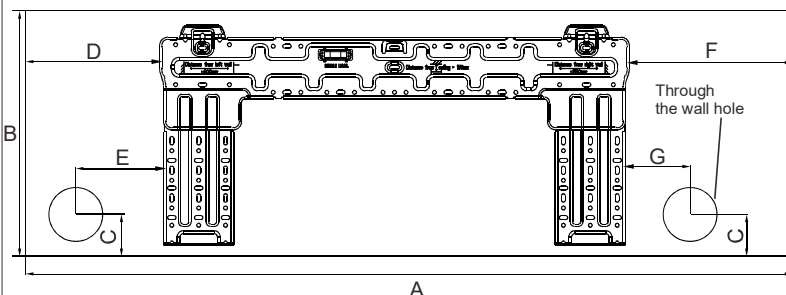

Dimension Model	18	24
A	39.29 (998)	44.92 (1141)
B	12.56 (319)	13.07 (332)
C	2.13 (54)	2.28 (58)
D	6.85 (174)	11.61 (295)
E	4.49 (114)	8.98 (228)
F	8.35 (212)	9.25 (235)
G	3.31 (84)	3.78 (96)

INDOOR UNIT INSTALLATION

Mounting Installation Plate

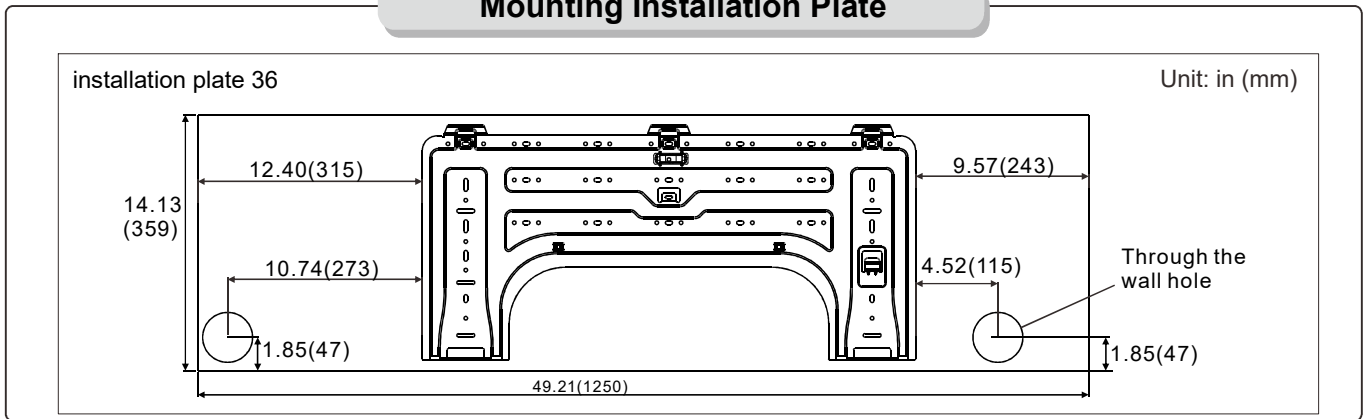

Wall-through Hole

1. Once a suitable location has been determined, drill hole with an outwardly slant of 5°-10° to ensure proper drainage.
2. Be sure to protect the piping and cables from damaged while running through the wall by using a pipe protecting ring or other field supplied protective device.
3. Use the supplied putty to seal the piping penetration to prevent mold buildup, rodents, and cold/hot air from entering the space.

Note:

Usually, the wall hole is $\Phi 2.36\text{in} \sim \Phi 3.15\text{in}$ ($\Phi 60\text{mm} \sim \Phi 80\text{mm}$).
Avoid pre-buried power wire and hard wall when making the hole.

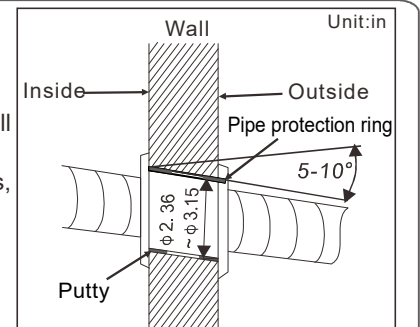

Route of Pipeline

1. The refrigerant piping can be routed out of the indoor unit a number of ways. For left, right, or bottom routing, use the cut-out holes on the casing of the unit. Bend the pipes carefully to the required position in order to align it with the hole.
2. For back routing, be sure to drill the hole in the proper place according the mounting bracket.
3. Wrap the inter-unit wire, refrigerant pipes, and drain hose together with insulation tape. (see Fig 1)

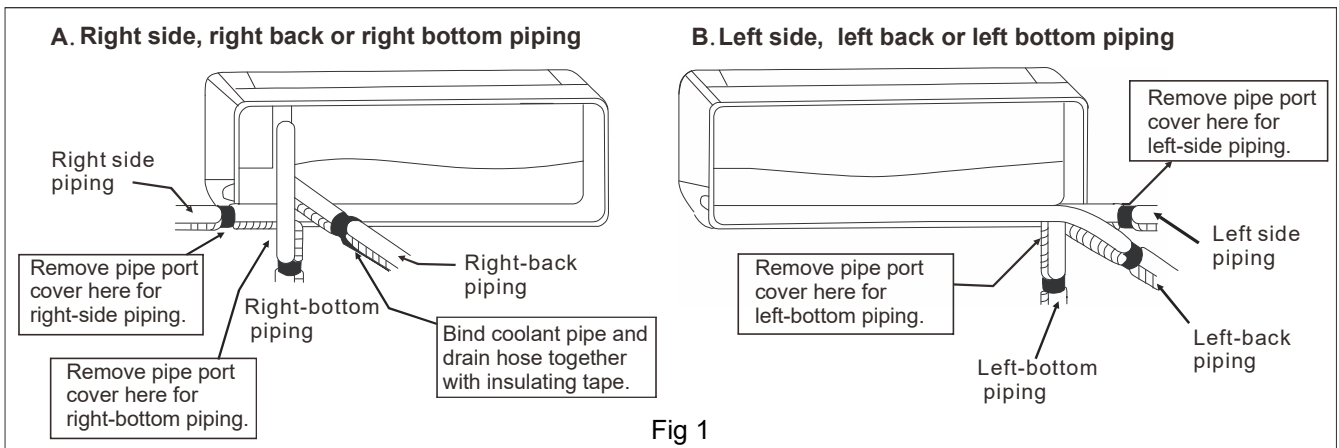

4. Bottom or side piping (see Fig 2)
 - a. Cut off pipe port cover with a coping saw.
 - b. Apply the blade of the coping saw to the notch, and cut off the pipe port cover along the uneven inner surface.
 - c. After cutting off the pipe cover, use a file to smooth the edges.

NOTE:

Bottom piping only applies to some units.

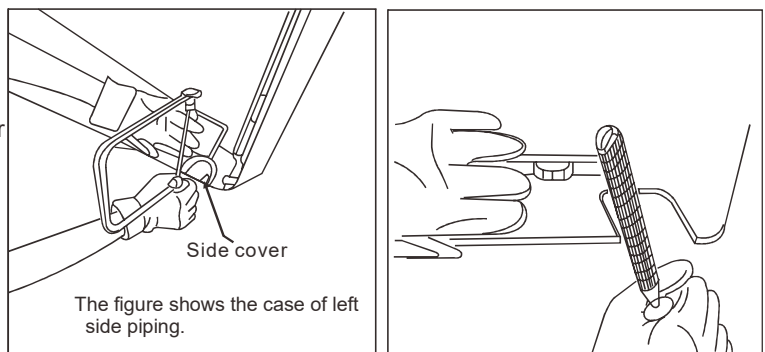

INDOOR UNIT INSTALLATION

Mount the Indoor Unit

1. Mount the unit onto the installation plate

Hook the indoor unit onto the upper portion of the installation plate (Engage the two hooks at the rear top of the indoor unit with the upper edge of the installation plate). Ensure that the hooks are properly seated on the installation plate by moving it to the left and right.

2. How to attach the indoor unit

Hook the claws of the bottom frame to the mounting plate.

3. Then connect the pipe of indoor unit as follows:

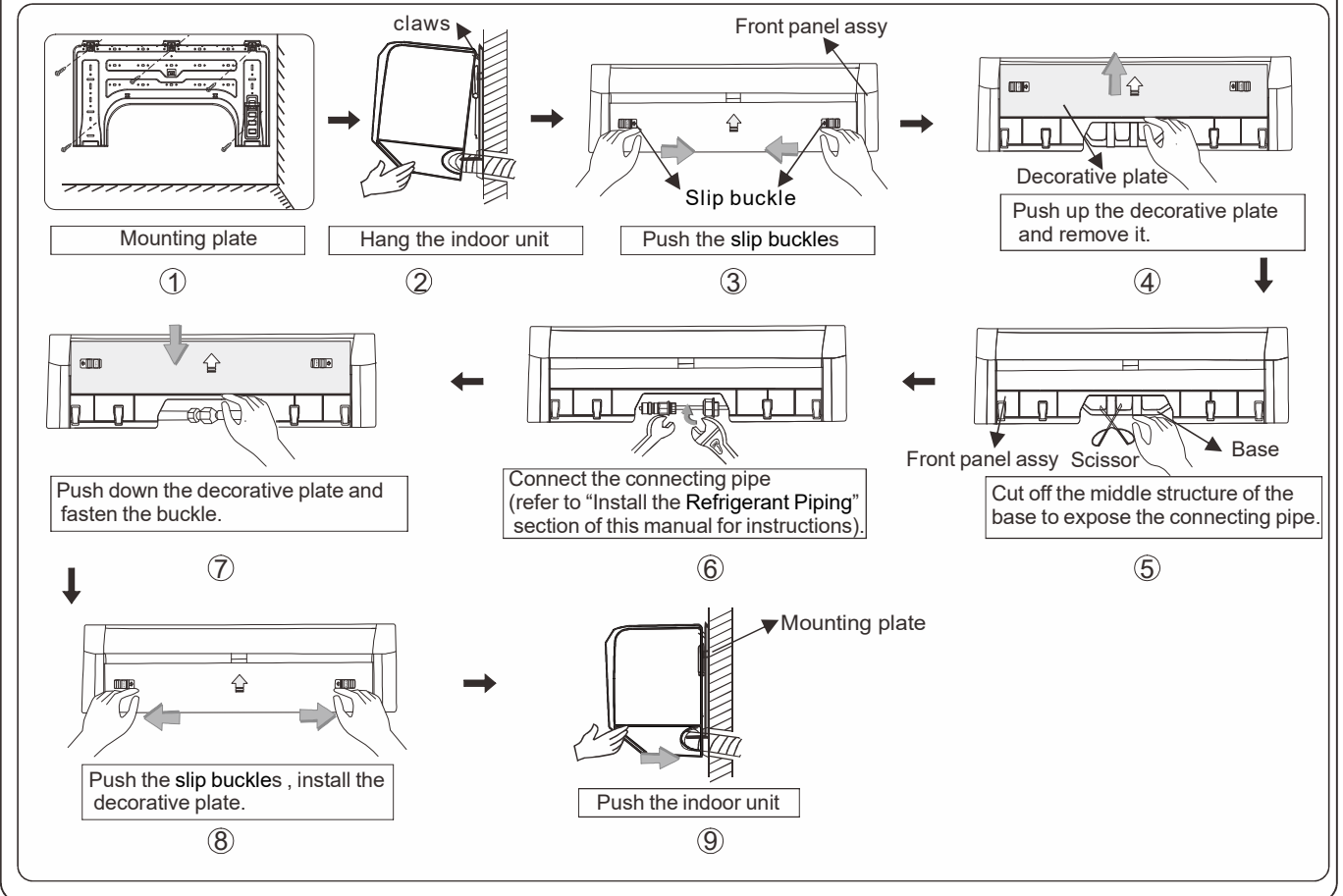

Wrap the Piping

1. Use the insulation sleeve to wrap the joint part the indoor unit and the connection pipe, and then use insulating material to pack and seal insulation pipe, to prevent generation of condensate water on the joint part.
2. Connect the water outlet with drain pipes, and make the connection pipe, cables, and the drain hose straight.
3. Use plastic cable ties to wrap the connecting pipes, cables and drain hose. Run the pipe sloping downward.

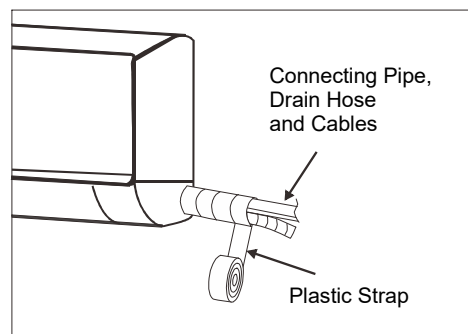
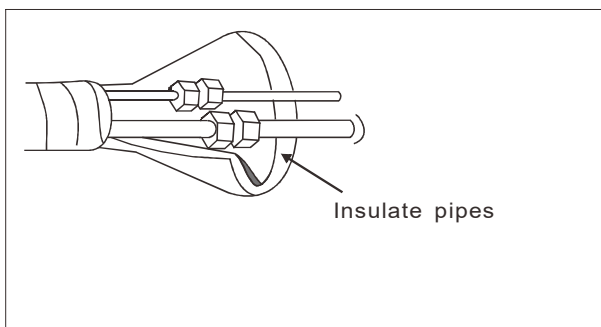

INDOOR UNIT INSTALLATION

Water Drainage Piping

The indoor drain pipe must be in a downward gradient for smooth drainage. Avoid situations that are likely to cause water to leak.

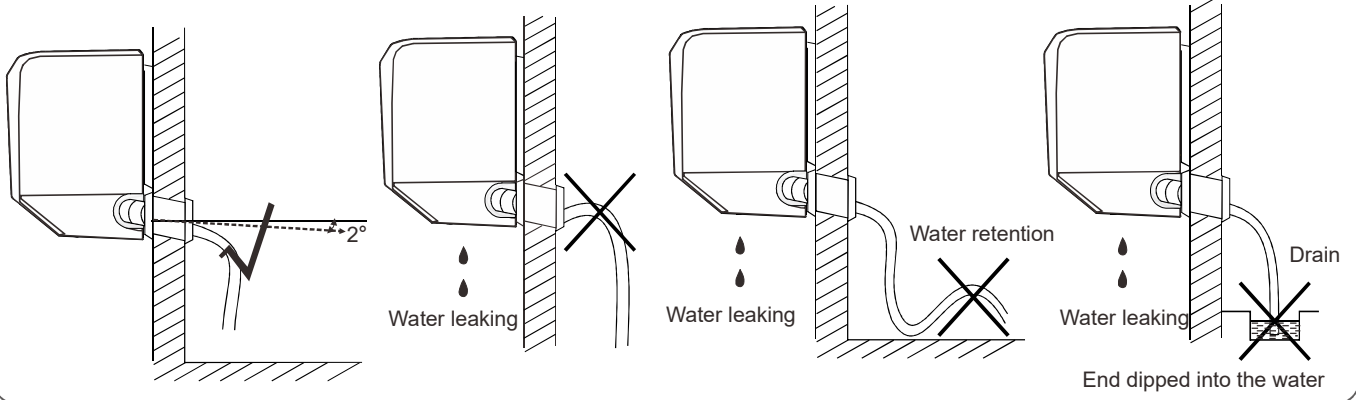

Install the Refrigerant Piping

Allowable Piping Length

If the pipe is too long, both the capacity and reliability of the unit will drop. As the number of bends increases, resistance to the flow of refrigerant system increases, thus lowering cooling capacity. As a result, the compressor may become defective. Always choose the shortest path and follow the recommendations as tabulated below:

Model	Indoor	07/09	12	18	24	36
	Outdoor	07/09	12	18	24	36
Min. Allowable Length (L), ft/(m)	9.84' (3)		9.84' (3)			
Max. Allowable Length (L), ft/(m)	65.6' (20)		98.4' (30)			
Max. Allowable Elevation (E), ft/(m)Gas	32.8' (15)		65.6' (20)			
Pipe Size, in/(mm)	3/8" (9.52)		1/2" (12.70)		5/8" (15.88)	
Liquid Pipe Size, in/(mm)	1/4" (6.35)		1/4" (6.35)			

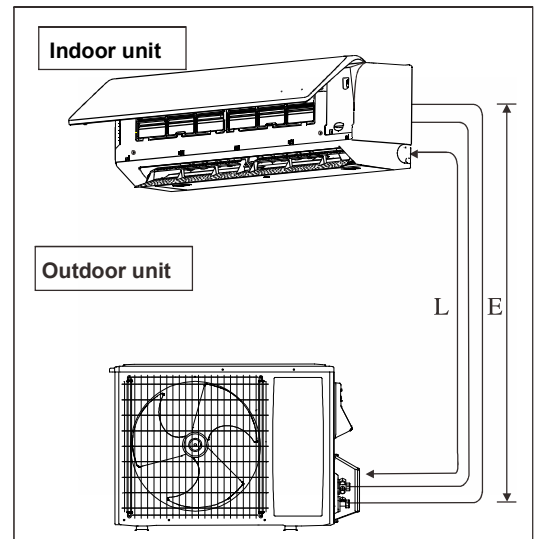

* Be sure to add the proper amount of additional refrigerant. Failure to do so may result in reduced performance. (See table on page 16 for additional refrigerant amounts)

Remark:

The refrigerant pre-charged in the outdoor unit is for piping lengths up to 25ft (7.6m).

Piping Works And Flaring Technique

- Do not use contaminated or damaged copper tubing. If the evaporator, condenser, or any piping has been open and exposed to the atmosphere for 15 seconds or more, the system must be vacuumed. Do not remove plastic plugs or brass nuts from piping connections until the connections are ready to be made.
- If any brazing work is required, ensure that a nitrogen gas purge is utilized to prevent soot formation on the inside wall of copper tubing. Failure to do so may cause damage to the unit and void warranty.
- Cut the pipe as straight as possible (See Fig 1.). Make sure to use a deburring tool to remove any burrs. Hold the pipe with opening facing down to prevent metal chips from entering the pipe (See Fig2.).

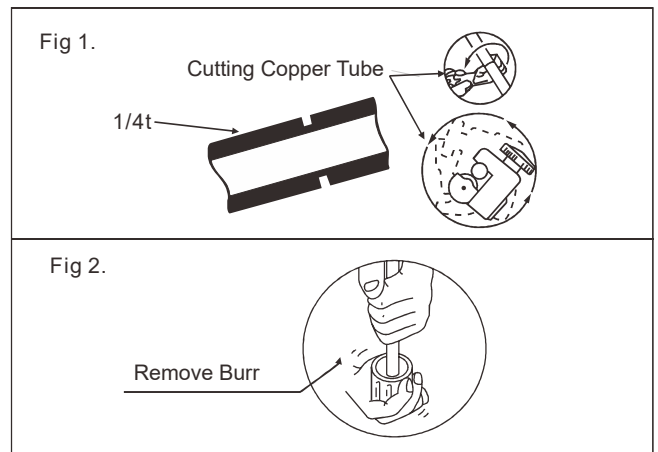

INDOOR UNIT INSTALLATION

Install the Refrigerant Piping

- This will avoid unevenness on the flare faces which will cause gas leak.
- Insert the flare nuts, mounted on the connection parts of both the indoor unit and outdoor unit, into the copper pipes.
- The exact length of pipe protruding from the top surface of the swaging block is determined by the flaring tool. See Fig 3.

- Fix the pipe firmly on the swaging block. Match the centers of both the swaging block and the flaring punch, then tighten the flaring punch fully.
- The refrigerant pipe connection are insulated by closed cell polyurethane.

Install the connection pipe

- Apply a slight amount of POE oil to the inside of the flare to prevent binding.
- Align the center of the piping and tighten the flare nut sufficiently with fingers. See Fig 4.
- Adjust the torque wrench to the proper torque settings according to the table. Finally, tighten the flare nut with torque wrench until the wrench clicks. When tightening the flare nut with the torque wrench, ensure that the tightening direction follows the arrow indicated on the wrench.

Fig 3.

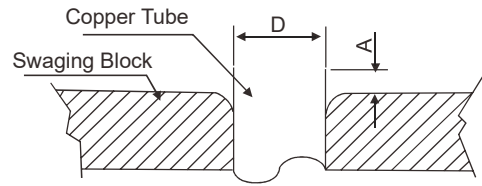

Ø Tube, D		A(Inch/mm)	
inch	mm	Imperial (Wing-nut Type)	Rigid (Clutch Type)
1/4"	6.35	0.051" (1.3)	0.028" (0.7)
3/8"	9.52	0.063" (1.6)	0.039" (1.0)
1/2"	12.70	0.075" (1.9)	0.051" (1.3)
5/8"	15.88	0.087" (2.2)	0.067" (1.7)
3/4"	19.05	0.098" (2.5)	0.079" (2.0)

Fig 4.

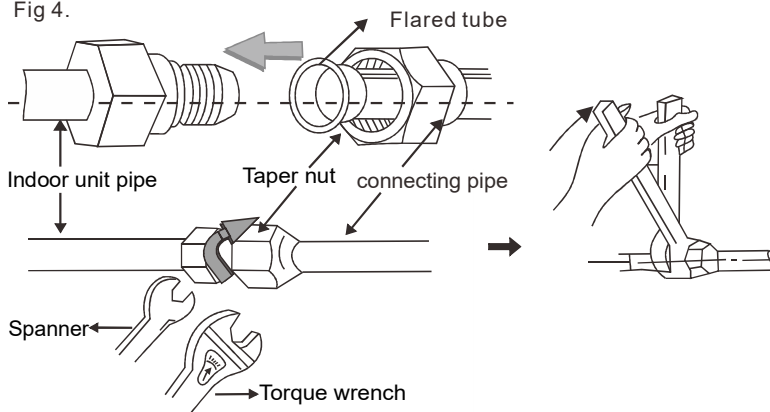

Tightening torque table

The size of pipe, in(mm)	Torque, ft-lb(N·m)
Ø1/4" (Ø6.35)	11.0-18.4 (15-25)
Ø3/8" (Ø9.52)	25.8-29.5 (35-40)
Ø1/2" (Ø12.7)	33.2-44.3 (45-60)
Ø5/8" (Ø15.88)	53.9-57.6 (73-78)
Ø3/4" (Ø19.05)	55.3-59.0 (75-80)

Electrical Wiring Connection

• Connect interconnection wire of indoor unit

1. Open the front panel of the unit and remove the screw on the wiring cover to access the unit wiring terminals.
2. Pull the wire through the cable-cross hole at the back of indoor unit and then pull it out from the front side of the unit with enough length to make the connections.
3. Remove the wire clip; connect the interconnection wires to the correct terminals according to the wiring diagram; Tighten the screw, and then fix the interconnection wire with wire clip.
4. Put wiring cover back and then tighten the screw.
5. Close the front panel.

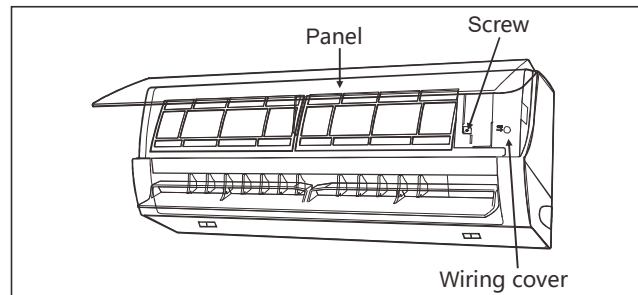

INDOOR UNIT INSTALLATION

Electrical Wiring Connection

NOTE:

✘ This manual usually includes the wiring mode for the different kind of air conditioner. We cannot exclude the possibility that some special type of wiring diagrams are not included.

✘ The diagram are for reference only. If the entity is difference with this wiring diagram, please refer to the detailed wiring diagram adhered on the unit which you purchased.

● After installation check

1. Make sure that the screws are tight and there is no risk of the wiring coming loose.
2. Verify that all wiring is tucked into unit nicely and there is no risk of wires being smashed by cover or touching the control board.
3. Inspect control box cover to verify proper installation.

Note:

Take care to ensure that all wiring between indoor unit and outdoor unit has a consistent connection. Any splices or breaks can cause communication errors and failure to start.

● Entire PCB replacement required if fuse failure occurs.

All wires must be firmly connected.

1. Make sure that none of the wiring is grounded to piping or compressor. Make sure no external pressure is applied to the terminal connectors and wires. Make sure all the covers are properly fixed to avoid any gaps. Use round crimp-style terminal connectors for connecting wires to the power supply terminal block. Connect the wires by matching the indication marks on the terminal block. (Refer to the wiring diagram attached on the unit).
2. Use the correct screwdriver for tightening the terminal screws. Unsuitable screwdrivers can damage the screw head. Over tightening can damage the terminal screws.
3. Do not connect wires of different gauge to same terminal.
4. Keep wiring in an orderly manner.
5. Prevent the wiring from obstructing other parts and the terminal box cover from closing.

When stripping the ends of interconnecting wires in advance, bind right ends of wires with insulating tape.

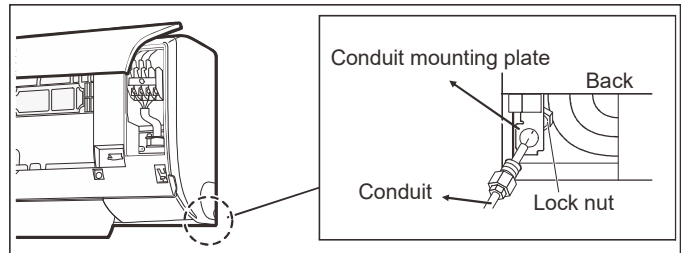
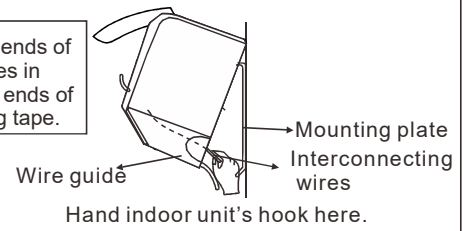

208-230V

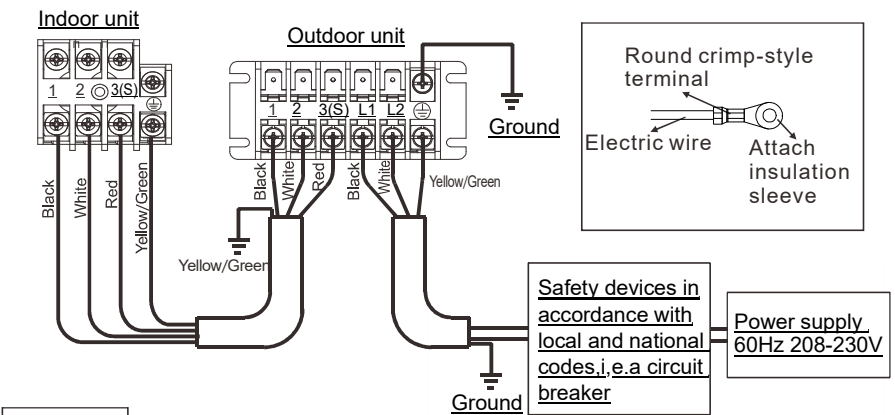

115V

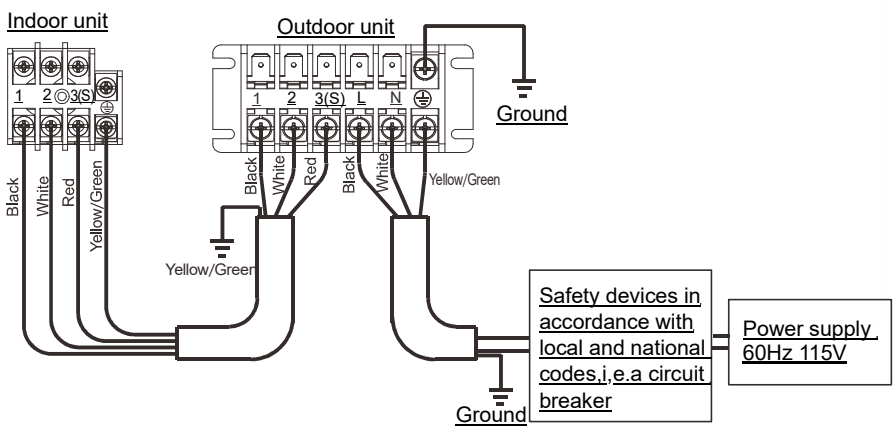

Power: 60Hz 208-230V

Recommended Wire Mode

Model	Power line(AWG)	Power connection line(AWG)
07/09K	3*16	4*20
12K	3*14	
18K		
24K		
36K		

Power: 60Hz 115V

Recommended Wire Mode

Model	Power line(AWG)	Power connection line(AWG)
07/09K	3*14	4*20
12K		

OUTDOOR UNIT INSTALLATION

Dimension Drawing of Outdoor Unit Installation

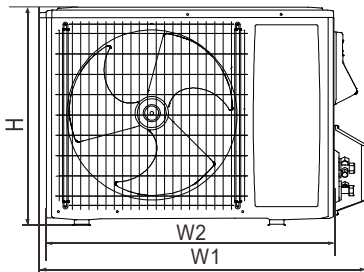
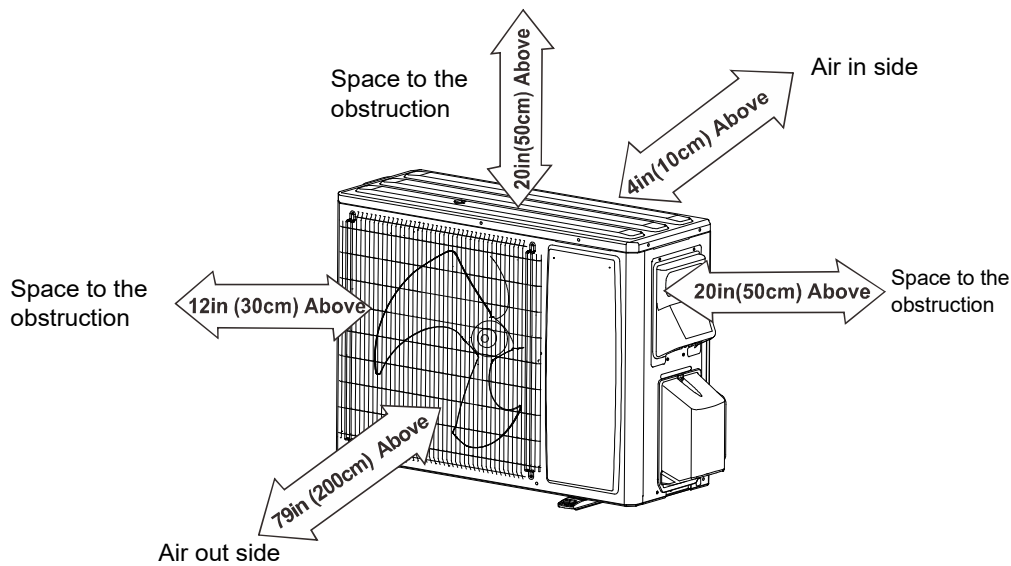

Installation outdoor unit bolt

Outdoor Unit Size of Shape W1 (W2)*H*D, in (mm)	A, in (mm)	B, in (mm)
31.7(28.0)×21.2×12.2 805(712)×538×309	18.9 (480)	11.1 (283)
34.7(31.0)×21.9×13.9 880(787)×557×353	21.5 (546)	12.4 (316)
38.6(35.3)×27.6×15.3 980(897)×700×388	24.9 (632)	13.9 (352)

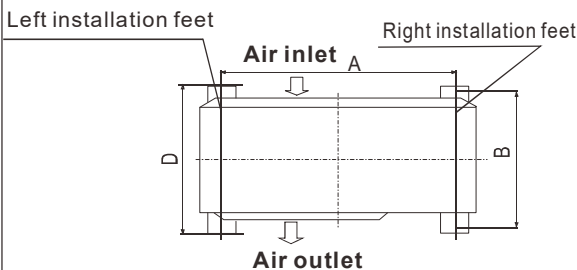

Where you install the outdoor unit will have a direct affect upon its performance.

In order for the outdoor unit to operate at its best you should carefully follow these instructions. In particular its important to prevent discharge air to return to the rear of the unit. This should be avoided as this will significantly reduce the cooling and heating performance.

- 1.The discharge air which is expelled from the front of the unit should not be allowed to immediately enter the return inlet of the back of the unit.
- 2.Ensure there is ample space in front of the unit will help prevent this from happening.
- 3.Ensure the unit is installed on a level surface and that there is plenty of room to service the equipment. Do not allow a slope of more than 5°.

The following figures show the right installation and wrong installation :

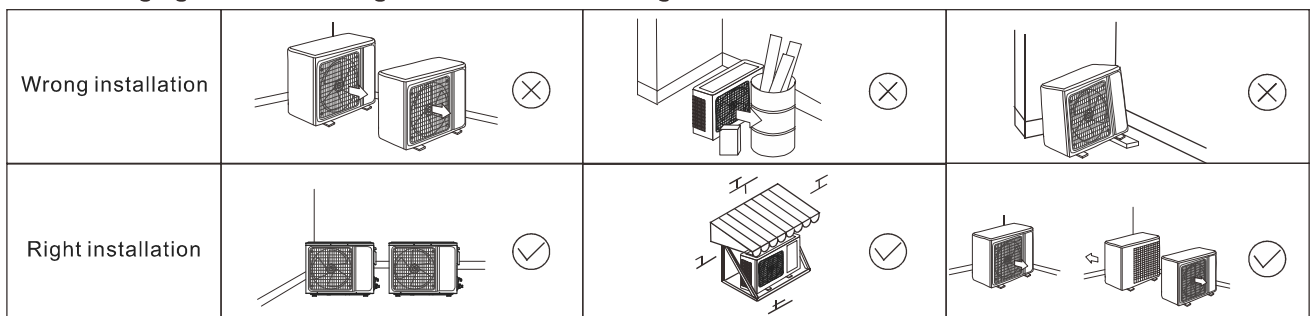

OUTDOOR UNIT INSTALLATION

Installation Guide at the Seaside

1. Air conditioners should not be installed in areas where corrosive gases, such as acid alkaline gas, are produced.

2. Do not install the product where it could be exposed to direct salt air.

Sea air exposure can result in corrosion on the unit. Corrosion, particularly on the condenser and evaporator fins, could cause product malfunction, inefficient performance, and refrigerant leaks.

3. If the outdoor unit is installed close to the seaside, it should avoid direct exposure to the sea wind. Otherwise, it may need additional anti corrosion treatment.

● Selecting the location (outdoor unit)

- The windbreak should be strong enough like concrete to prevent the sea wind from hitting the unit. The height and width should be more than 150% of the outdoor unit.

4. Select a well-drained place. Install the outdoor unit on the opposite side of the direction of the sea wind, or set up a windbreak to avoid exposed to the sea wind.

Seaside applications will require more frequent maintenance checks and cleaning. Be sure to keep the system free of salt build up by washing the unit with clean water at low pressure.

- The unit should be kept more than 27.6in (70cm) from the windbreak for easy air flow.

● The mounting rack of the outdoor unit shall be fastened with expansion bolts or as the manufacture recommends.

● If installing on a wall, ensure the secure installation regardless of the type of to prevent potential dropping that could damage the unit or cause injury.

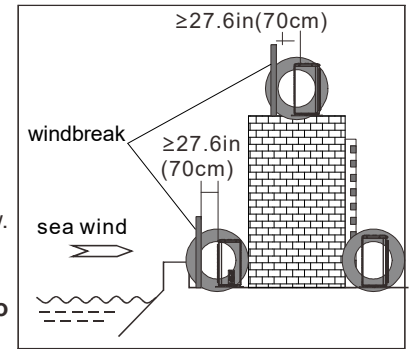
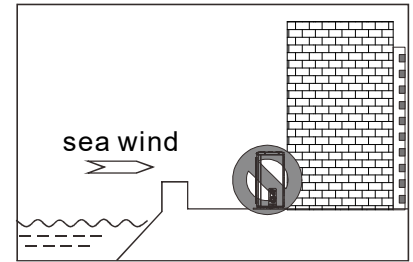

Outdoor Condensation Drainage(Heat pump type only)

When the unit is in heating mode, the outdoor unit can generate water that will drip from the bottom of the unit. To control the flow of that water, please use the provided drain elbow.

Installation :

1). Install the drain elbow in the 1in(Φ25mm) hole on the bottom of the base plate, and connect the drain hose to the elbow. Route the hose to a location so that the water formed in the outdoor unit can be drained out to a proper location.

2). In cold areas, do not use a the drain elbow or drain plugs on the outdoor unit. Plugging the holes will cause ice to buildup in the base pan which could result in damage to the unit. In cold climates, make sure the unit has plenty of space to drain and avoid snow drifts.

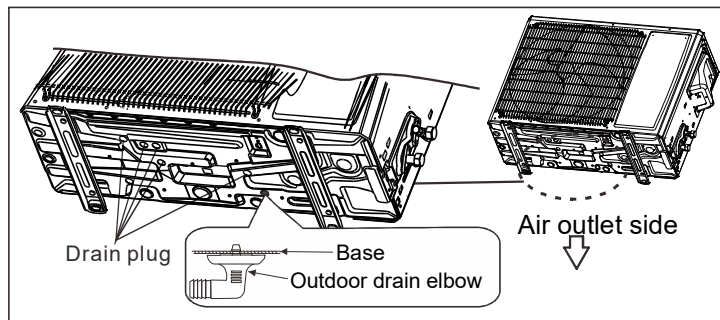

Install the Connection Pipe

Additional refrigerant may be required based on the length of the refrigerant pipe. The chart below shows the requirements of refrigerant needed based of the piping length.

The additional refrigerant is required to ensure proper performance and prevent damage to the unit.

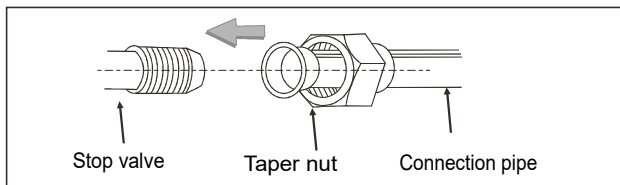

Size of unit	Length of connection pipe	Added refrigerant
All	9.8-25ft (3-7.6m)	Not needed
07K, 9K, & 12K	25-65.6ft (7.6-20m)	add 0.172oz/ft(16g/m)
18K, 24K, & 36K	25-98.4ft (7.6-30m)	add 0.258oz/ft(24g/m)

Note:

1. The flares shall not be reused. It is important to always re-flare pipes upon their removal and reinstallation.

2. After installation, check the stop valve cover for proper installation.

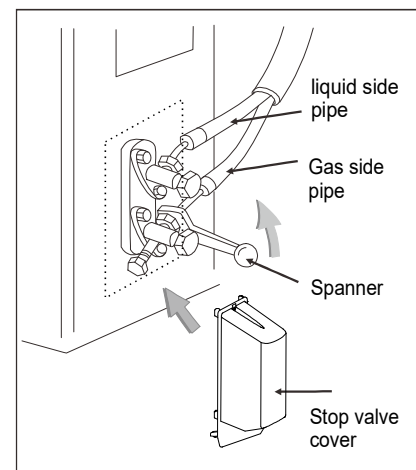

OUTDOOR UNIT INSTALLATION

Wiring Connection

1. Loosen the screws and remove the E-parts cover from the unit.
2. Connect the cables respectively to the corresponding terminals of the terminal board of the outdoor unit (see the wiring diagram), using ring connectors.
3. Ground wire: Remove the grounding screw out of the electric bracket, connect the grounding wire end onto the grounding screw and screw it into the grounding hole.
4. Fix the cable securely with ring connectors
5. Put the E-parts cover back in its original place and fasten it with screws.

NOTE:

- This manual usually includes the wiring mode for the different kind of air conditioner. We cannot exclude the possibility that some special types of wiring diagrams are not included.
- The diagrams are for reference only. Please refer to the detailed wiring diagram adhered on the unit which you purchased.

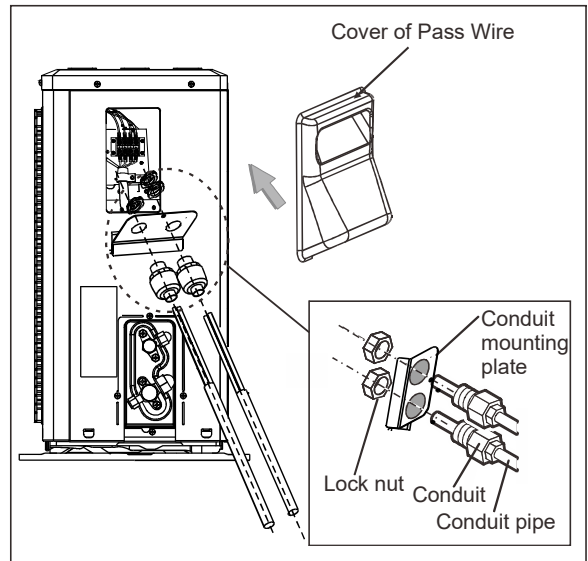

Vacuumping

The refrigerant of R32 model must be evacuated (R410A vacuum pump can be used).

Before working on the air conditioner, remove the cover of the stop valve (gas and liquid valves, be sure to re-tighten it afterward to prevent the potential air leakage).

1. To prevent air leakage, make sure all flares are properly connected and torqued.
2. Connect the stop valve, charge hose, manifold valve, and vacuum pump to the unit.
3. Fully open the handle of the manifold valve and apply vacuum for at least 15 minutes and check that the compound vacuum gauge reads -14.7psi (-76cmHg).
4. After applying vacuum, fully open the stop valve with a hex wrench.
5. Check that both indoor and outdoor connections are free of air leakage.

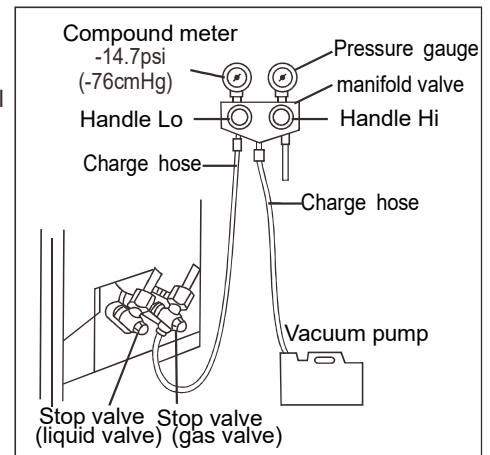

TESTING AND INSPECTION

Check After Installation

- **Electrical Safety Check**

1. If the supply voltage is within tolerance.
2. If the indoor and outdoor units are properly wired.
3. If the grounding wire of the air conditioner is securely grounded.

- **Installation Safety Check**

1. If the unit is mounted properly and securely.
2. If the water drains smoothly from indoor unit to outdoor drain.
3. If the wiring and piping are correctly installed and free of leaks.
4. Check that no foreign matter or tools are left inside the unit.
5. Check the refrigerant pipeline and connections are properly insulated.

- **Leak test of the refrigerant**

Depending on the installation method, the following methods may be used to check for suspect leak, on areas such as the connections of the outdoor unit and the cores of the cut-off valves and t-valves:

1. Bubble method: Apply of spray a uniform layer of soap water over the suspected leak spot and observe carefully for bubble.
2. Instrument method: Checking for leak by pointing the probe of the leak detector according to the instruction to the suspect points of leak.

Note:

Make sure that the ventilation is good before checking.

Test Operation

- **Test Operation preparation:**

1. Verify that all piping and wiring is properly connected.
2. Confirm that the valve at the gas side and the liquid-side are fully open.
3. Verify that power is turned on to the unit.
4. Install batteries in the remote control.

Note:

Make sure that the ventilation is good before testing.

- **Test Operation method:**

1. Turn on the power and push the ON/OFF switch button of the remote controller to start the air conditioner.
2. Select COOL or HEAT, adjust the SWING and other operation modes with the remote controller to verify proper operation.

- **Attention:**

1. For maintenance or scrap, please contact authorized service contractors.
2. Maintenance by unqualified person may cause injury or death.
3. Charge the air conditioner with R32 refrigerant, and maintain the air conditioner in strict accordance with manufacturer's requirements. The chapter is mainly focused on special maintenance requirements for appliance with R32 refrigerant.
4. Ask repairer to read after-sales technical service handbook for detailed information.

CARE AND CLEANING

WARNING

Before cleaning the air conditioner, the unit must be shut down and the electricity must be cut off for more than 5 minutes, otherwise there might be the risk of electric shock.

- Do not expose electrical connections or electronics to moisture which can cause an electric shock.
- Volatile liquid such as thinner or gasolin will damage the air conditioner, therefore only clean the housing of air conditioner with soft dry cloth or a cloth that is slightly dampened with water.
- Make sure to check filters regularly to prevent the accumulation of dust which may affect the air conditioner performance. If the unit is installed in an environment that has more dust, the number of cleanings will need to increase. After removing the filter, do not touch the fin part of the indoor unit with your fingers as it may result in damage to the unit or injury.

CARE AND CLEANING

Clean the Panel

When the panel of the indoor unit is dirty, clean it with soft dry cloth or a cloth that is slightly dampened with water.

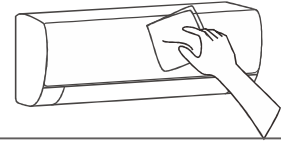

Clean the Air Filter

Remove the air filter

1. Use both hands to open the front panel to gain access to the filters.
2. Gently release the air filter from the slot and remove.

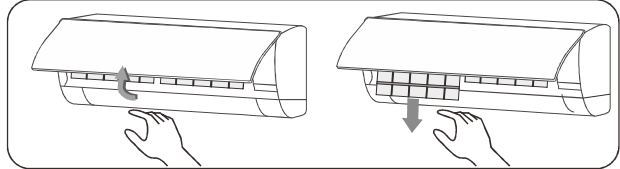

Clean the Air Filter

Use a vacuum cleaner or water to rinse the filter clean. If the filter is very dirty (for example, with greasy dirt), clean it with warm water (below 113°F (45°C)) with a mild detergent. Put the filter in a shady area to dry in the air.

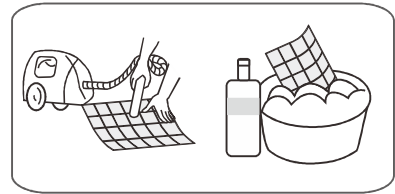

Clean or replacement the Activated carbon filter screen

1. Cleaning: you can clean with the Air Filter;
2. Replacement: remove the filter from the filter frame and attach a new one.

Note:

Do not throw away the filter frame.
Reuse the filter frame when replacing the activated carbon filter screen. When attaching the filter, check that the filter is properly set in the tabs. Dispose of the old filter as non-flammable waste

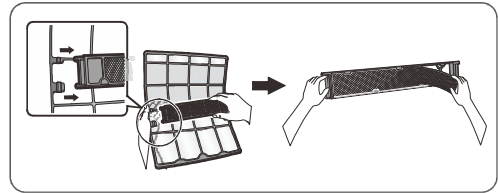

Mount the Filter

Reinstall the dried filter in reverse order of removal, then gently close the front cover and lock the panel.

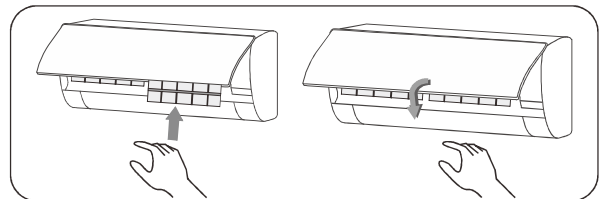

Check Before Using

1. Make sure that all the air inlets and outlets of the units are unblocked.
2. Check whether the indoor unit drains properly.
3. Check the ground wire is securely grounded.
4. Check whether the remote-control batteries are installed and in proper operating condition.
5. Verify that the outdoor unit is securely mounted and free from damage. If any issues, please contact our local contractor for inspection.

Maintain After Using

1. Turn off the power source of the air conditioner at the outdoor unit.
2. Clean the indoor unit panel and filter.
3. Remove the dust and debris from the outdoor unit.
4. Verify that the outdoor unit is securely mounted and free from damage. If any issues, please contact our local contractor for inspection.

TROUBLESHOOTING

⚠ CAUTION

Do not attempt to repair the air conditioner by yourself as wrong maintenance may cause electric shock, fire, or explode. Please contact a authorized contractor and let the professionals conduct the maintenance and repairs. Checking the below items prior to contacting a contractor can help identify a potential problem.

Phenomenon	Troubleshooting
<p>The air blows out of the indoor unit, but the air is not being cooled/heated.</p>	<ul style="list-style-type: none"> • Excessive accumulation of dust on filter, blocking the air inlet or outlet → Please clean the filter, remove the obstacles at the air inlet • The louver blades are at an excessively angle limiting airflow. → Please adjust the louvers to pointing straight. • Poor cooling and heating effect caused by doors and windows opening, and unclosed exhaust fan. → Please close the doors, windows, the exhaust fan, etc. • Auxiliary heating function is not turned on while heating, which may lead to poor heating effect. → Turn on the auxiliary heating function. (only for models with auxiliary heating function) • Mode setting is incorrect, and the temperature and wind speed settings are not appropriate. → Please re-select the mode, and set the appropriate temperature and wind speed.
<p>The indoor unit blows out odor.</p>	<ul style="list-style-type: none"> • The air conditioner itself does not have undesirable odor. If there is odor, it may be due to accumulation of the odor in the environment. → Clean the air filter or activate the cleaning function.
<p>There is sound of running water during operation of the system.</p>	<ul style="list-style-type: none"> • When the air conditioner is started up or stopped the system can make a "hissing" sound that might sound like running water. → This is the sound of the flow of the refrigerant and not a malfunction.
<p>A slight "click" sound is heard at the of start-up or shut-down.</p>	<ul style="list-style-type: none"> • Due to temperature changes, panel and other parts will swell, causing the sound of friction. → This is normal, not a fault.
<p>The indoor unit makes abnormal sound.</p>	<ul style="list-style-type: none"> • The sound of fan or compressor relay switched on or off. • When the defrosting is started or stop running, it will create sound. → That is due to the refrigerant flows to reverse direction. They are not malfunctions. • Too much dust accumulation on the air filter of the indoor unit may result in fluctuation of the sound. → Clean the air filters in time. • Too much air noise when "Strong wind" is turned on. → This is normal, if feeling uncomfortable, please deactivate the "Strong wind" function.
<p>There are water drops over the surface of the indoor unit.</p>	<ul style="list-style-type: none"> • When ambient humidity is high, water drops will be accumulated around the air outlet or the panel, etc. → This is a normal physics phenomenon. • Prolonged cooling run in open space produces water drops. → Close the doors and windows. • Too small opening angle of the louver blades may also result in water drops at the air inlet. → Increase the angle of the louver blades.

TROUBLESHOOTING

Phenomenon	Troubleshooting
During the cooling operation, the indoor unit outlet sometimes will blow out mist.	<ul style="list-style-type: none">• When the indoor temperature and humidity are high, it happens sometimes. → This is because the indoor air is cooled rapidly. After it runs for some time, the indoor temperature and humidity will be reduced and the mist will disappear.
The air conditioner does not work.	<ul style="list-style-type: none">• There might be power outages. → Wait until power is restored.• The wires may loose. → Re-tighten the wires.• Power switch fuse may blow. → Replace the fuse.• The time for timing boot is yet to come. → Wait or cancel the timer settings.
The air conditioner can't run after the immediate start-up after it is shut down.	<ul style="list-style-type: none">• If the air conditioner is turned on immediately after it is turned off, the protective delay switch will delay the operation for 3 to 5 minutes.
The air conditioner stops running after it starts up for a while.	<ul style="list-style-type: none">• May have reached the setting temperature. → It is a normal function phenomenon.• May be at a defrosting state. → It will automatically restore and run again after defrosting.• Shutdown Timer may be set. → If you continue to use, please turn it on again.

 **Immediately stop all operations and cut off the power supply ,contact our Service center locally in following situations.**

- ▲ Hear any harsh sound or smell any awful odor during running.
- ▲ Abnormal heating of power cable .
- ▲ The unit or remote controller has been exposed to excessive amounts of water.
- ▲ Circuit breaker continuously trips.

MAINTENANCE NOTICE

Attention :

For maintenance or scrap, please contact a authorized contractor.

Maintenance by unqualified person may cause injury or damage to the unit.

Charge air conditioner with R32 refrigerant only, and maintain the air conditioner in a strict accordance with manufacturer's requirements.

Qualification Requirements of Maintenance Personnel

1. Special training is required to work on equipment with A2L refrigerants. Only rely on qualified contractors to install, service, and repair this system.
 2. The maintenance and repair of the air conditioner must be conducted according to the method recommended by the manufacturer.
- If other professionals are needed to help maintain and repair the equipment, it should be conducted under the supervision of individuals who have the qualification to repair AC equipped with flammable refrigerants.

Inspection of the Site

Safety inspection must be conducted before maintaining equipment with R32 refrigerant to make sure the risk of fire is minimized.

Check whether the space is well ventilated and whether anti-static or fire prevention equipment is required.

While maintaining the refrigeration system, observe the following precautions before operating the system.

Operating Procedures

1. General work area:

All maintenance staff and others working in the local area shall be instructed on the nature of work being carried out. Work in confined spaces shall be avoided. The area around the workspace shall be sectioned off. Ensure that the conditions within the area have been made safe by control of flammable material.

2. Checking for presence of refrigerant:

The area shall be checked with an appropriate refrigerant detector prior to and during work, to ensure the technician is aware of potentially toxic or flammable atmospheres.

Ensure that the leak detection equipment being used is suitable for use with all applicable refrigerants, i.e. non-sparking, adequately sealed or intrinsically safe.

3. Presence of fire extinguisher:

If any hot work is to be conducted on the refrigeration equipment or any associated parts, appropriate fire extinguishing equipment shall be available to hand. Have a dry powder or CO₂ fire extinguisher adjacent to the charging area.

4. No ignition sources:

No person carrying out work in relation to a refrigeration system which involves exposing any pipe work shall use any sources of ignition in such a manner that it may lead to the risk of fire or explosion. All possible ignition sources, including cigarette smoking, should be kept sufficiently far away from the site of installation, repairing, removing and disposal, during which refrigerant can possibly be released to the surrounding space. Prior to work taking place, the area around the equipment is to be surveyed to make sure that there are no flammable hazards or ignition risks. 'No Smoking' signs shall be displayed.

5. Ventilated Area(open the door and window):

Ensure that the area is in the open or that it is adequately ventilated before breaking into the system or conducting any hot work. A degree of ventilation shall continue during the period that the work is carried out. The ventilation should safely disperse any released refrigerant and preferably expel it externally into the atmosphere.

6. Checks to the refrigeration equipment:

Where electrical components are being changed, they shall be fit for the purpose and to the correct specification. At all times the manufacturer's maintenance and service guidelines shall be followed. If in doubt, consult the manufacturer's technical department for assistance. The following checks shall be applied to installations using flammable refrigerants:

- The charge size is in accordance with the room size within which the refrigerant containing parts are installed.
- The ventilation machinery and outlets are operating adequately and are not obstructed.
- If an indirect refrigerating circuit is being used, the secondary circuit shall be checked for the presence of refrigerant.
- Refrigeration pipe or components are installed in a position where they are unlikely to be exposed to any substance which may corrode refrigerant containing components, unless the components are constructed of materials which are inherently resistant to being corroded or are suitably protected against being so corroded.

MAINTENANCE NOTICE

Operating Procedures

7. Checks to electrical devices:

Repair and maintenance to electrical components shall include initial safety checks and component inspection procedures. If a fault exists that could compromise safety, then no electrical supply shall be connected to the circuit until it is satisfactorily dealt with. If the fault cannot be corrected immediately but it is necessary to continue operation, an adequate temporary solution shall be used. This shall be reported to the owner of the equipment so all parties are advised. Initial safety checks shall include:

- That capacitors are discharged: this shall be done in a safe manner to avoid possibility of sparking.
- That no live electrical components and wiring are exposed while charging, recovering or purging the system.
- Keep continuity of earthing.

Inspection of Cable

Check the cable for wear, corrosion, overvoltage, vibration and check if there are sharp edges and other adverse effects in the surrounding environment. During the inspection, the impact of aging or the continuous vibration of the compressor and the fan on it should be taken into consideration.

Leakage Check of R32 Refrigerant

Note: Check the leakage of the refrigerant in an environment where there is no potential ignition source.

No halogen probe (or any other detector that uses an open flame) should be used.

Leak detection method:

For systems with refrigerant R32, electronic leak detection instrument is available to detect and leak detection should not be conducted in environment with refrigerant. Make sure the leak detector will not become a potential source of ignition, and is applicable to the measured refrigerant. Leak detector shall be set for the minimum ignitable fuel concentration (percentage) of the refrigerant. Calibrate and adjust to proper gas concentration (no more than 25%) with the used refrigerant.

The fluid used in leak detection is applicable to most refrigerants. But do not use chloride solvents to prevent the reaction between chlorine and refrigerants and the corrosion of copper pipeline.

If you suspect a leak, then remove all the fire from the scene or put out the fire.

If the location of the leak needs to be welded, then all refrigerants need to be recovered, or, isolate all refrigerants away from the leak site (using cut-off valve). Before and during the welding, use OFN to purify the entire system.

Removal and Vacuum Pumping

1. Make sure there is no ignited fire source near the outlet of the vacuum pump and the ventilation is well.

2. Allow the maintenance and other operations of the refrigeration circuit should be carried out according to the general procedure, but the following best operations that the flammability is already taken into consideration are the key.

You should follow the following procedures:

- Remove the refrigerant.
 - Decontaminate the pipeline by inert gases.
 - Evacuation.
 - Decontaminate the pipeline by inert gases again.
 - Cut or weld the pipeline.
3. The refrigerant should be returned to the appropriate storage tank. The system should be blown with oxygen free nitrogen to ensure safety. This process may need to be repeated for several times. This operation shall not be carried out using compressed air or oxygen.
4. Through blowing process, the system is charged into the anaerobic nitrogen to reach the working pressure under the vacuum state, then the oxygen free nitrogen is emitted to the atmosphere, and in the end, vacuumize the system. Repeat this process until all refrigerants in the system is cleared. After the final charging of the anaerobic nitrogen, discharge the gas into the atmosphere pressure, and then the system can be welded. This operation is necessary for welding the pipeline.

MAINTENANCE NOTICE

Procedures of Charging Refrigerants

As a supplement to the general procedure, the following requirements need to be added:

- Make sure that there is no contamination among different refrigerants when using a refrigerant charging device. The pipeline for charging refrigerants should be as short as possible to reduce the residual of refrigerants in it.
- Storage tanks should remain vertically up.
- Make sure the grounding solutions are already taken before the refrigeration system is charged with refrigerants.
- After finishing the charging (or when it is not yet finished), label the mark on the system.
- Be careful not to overcharge refrigerants.

Scrap and Recovery

Scrap:

Before this procedure, the technical personnel shall be thoroughly familiar with the equipment and all its features, and make a recommended practice for refrigerant safe recovery. For recycling the refrigerant, shall analyze the refrigerant and oil samples before operation. Ensure the required power before the test.

1. Be familiar with the equipment and operation.
2. Disconnect power supply.
3. Before carrying out this process, you have to make sure:
 - If necessary, mechanical equipment operation should facilitate the operation of the refrigerant tank.
 - All personal protective equipment is effective and can be used correctly.
 - The whole recovery process should be carried out under the guidance of qualified personnel.
 - The recovering of equipment and storage tank should comply with the relevant national standards.
4. If possible, the refrigerating system should be vacuumized.
5. If the vacuum state can't be reached, you should extract the refrigerant in each part of the system from many places.
6. Before the start of the recovery, you should ensure that the capacity of the storage tank is sufficient.
7. Start and operate the recovery equipment according to the manufacturer's instructions.
8. Don't fill the tank to its full capacity (the liquid injection volume does not exceed 80% of the tank volume).
9. Even the duration is short, it must not exceed the maximum working pressure of the tank.
10. After the completion of the tank filling and the end of the operation process, you should make sure that the tanks and equipment should be removed quickly and all closing valves in the equipment are closed.
11. The recovered refrigerants are not allowed to be injected into another system before being purified and tested.

Note: The identification should be made after the appliance is scrapped and refrigerants are evacuated.

The identification should contain the date and endorsement. Make sure the identification on the appliance can reflect the flammable refrigerants contained in this appliance.

Recovery:

1. The clearance of refrigerants in the system is required when repairing or scrapping the appliance. It is recommended to completely remove the refrigerant.
2. Only a special refrigerant tank can be used when loading the refrigerant into the storage tank. Make sure the capacity of the tank is appropriate to the refrigerant injection quantity in the entire system. All tanks intended to be used for the recovery of refrigerants should have a refrigerant identification (i.e. refrigerant recovery tank).
Storage tanks should be equipped with pressure relief valves and globe valves and they should be in a good condition. If possible, empty tanks should be evacuated and maintained at room temperature before use.
3. The recovery equipment should be kept in a good working condition and equipped with equipment operating instructions for easy access. The equipment should be suitable for the recovery of R32 refrigerants.
Besides, there should be a qualified weighting apparatus which can be normally used.
The hose should be linked with detachable connection joint of zero leakage rate and be kept in a good condition. Before using the recovery equipment, check if it is in a good condition and if it gets perfect maintenance. Check if all electrical components are sealed to prevent the leakage of the refrigerant and the fire caused by it. If you have any question, please consult the manufacturer.
4. The recovered refrigerant shall be loaded in the appropriate storage tanks, attached with a transporting instruction, and returned to the refrigerant manufacturer. Don't mix refrigerant in recovery equipment, especially a storage tank.
5. The space loading R32 refrigeration can't be enclosed in the process of transportation. Take anti electrostatic measures if necessary in transportation. In the process of transport, loading and unloading, necessary protective measures must be taken to protect the air conditioner to ensure that the air conditioner is not damaged.
6. When removing the compressor or clearing the compressor oil, make sure the compressor is pumped to an appropriate level to ensure that there is no residual R32 refrigerants in the lubricating oil. The vacuum pumping should be carried out before the compressor is returned to the supplier. Ensure the safety when discharging oil from the system.

DE-COMMISSIONING,DISMANTLING&DISPOSAL

This product contains refrigerant under pressure, rotating parts, and electrical connections which may be a danger & cause injur. All work must only be carried out by competent persons using suitable protective clothing and safety precautions.



Read the Manual



Risk of Electric Shock

RoHS



Unit is Remotely controlled
& may start without warning



1. Isolate all sources of electrical supply to the unit including any control system supplies switched by the unit. Ensure that all points of electrical and gas isolation are secured in the OFF position. The supply cables and gas pipe work may then be disconnected and removed. For points of connection refer to unit installation instructions.
2. Remove all refrigerant from each system of the unit into a suitable container using a refrigerant reclaim or recovery unit. This refrigerant may then be reused, if appropriate, or returned to the manufacturer for disposal. Under no circumstances should refrigerant be vented to atmosphere. Where appropriate, drain the refrigerant oil from each system into a suitable container and dispose of according to local laws and regulations governing disposal of oily wastes.
3. Packaged units can generally be removed in one piece after disconnection as above. Any fixing down bolts should be removed and then unit lifted from position using the points provided and equipment of adequate lifting capacity. Reference **MUST** be made to the unit installation instructions for unit weight and correct methods of lifting. Note that any residual or spilt refrigerant oil should be mopped up and disposed of as described above.
4. After removal from position the unit parts may be disposed of according to local laws and regulations.
5. Meaning of crossed Out wheeled dustbin: Do not dispose of electrical appliances as unsorted municipal waste, use separate collection facilities. Contact your local government for information regarding the collection systems available. If electrical appliances are disposed of in landfills or dumps, hazardous substances can leak into the groundwater and get into the food chain, damaging your health and well being. When replacing old appliances with new ones, the retailer is legally obligated to take back your old appliance for disposals at least free of charge.



MADE IN CHINA

11326001001005